

# UIC PALLETS DATA SHEET



UIC pallets provide a cost-effective and reliable solution for customers who are looking for an alternative to standard EPAL pallets, but don't want to compromise on quality and durability. Manufactured using high quality timber, our pallets guarantee exceptional physical resistance and durability, making them the ideal choice for transporting and storing a wider range of goods, from heavy equipment to lightweight consumer goods. The cost-effectiveness of these pallets makes them particularly attractive to companies looking to optimise their logistics costs while maintaining high standards of safety and security of their goods during transport and storage. UIC pallets are

manufactured in full compliance with environmental standards, from the selection of raw materials to production techniques that minimise waste and energy consumption. The wood used comes from forests where responsible forestry is practised, guaranteeing the preservation of biodiversity and ecosystems. After their useful life is over, the pallets can be easily recycled, helping to reduce waste and keep resources cycling. So, by choosing our pallets, you not only get a reliable and cost-effective product for your business, but you also contribute to protecting the environment and upholding the principles of sustainable development.

## AVAILABLE TYPES & SPECIFICATION



### AVAILABLE TYPES

SKU	STANDARD	Colour	LENGTH	WIDTH	CONDITION	CHOICE
001.201	EUR-1	BRIGHT	800 MM	1200 MM	NEW	N/A
001.202	EUR-1	BRIGHT	800 MM	1200 MM	USED	1 <sup>st</sup> CHOICE
001.203	EUR-1	DARK	800 MM	1200 MM	USED	2 <sup>nd</sup> CHOICE

### DIMENSIONS, WEIGHT, SAFE LOAD

LENGTH	800 MM
WIDTH	1200 MM
HEIGHT	144 MM
WEIGHT	±25 KG
SAFE WORKING LOAD	1500 KG

### MARKINGS

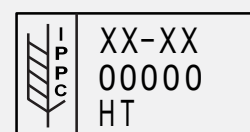

### 800 MM SIDE

---

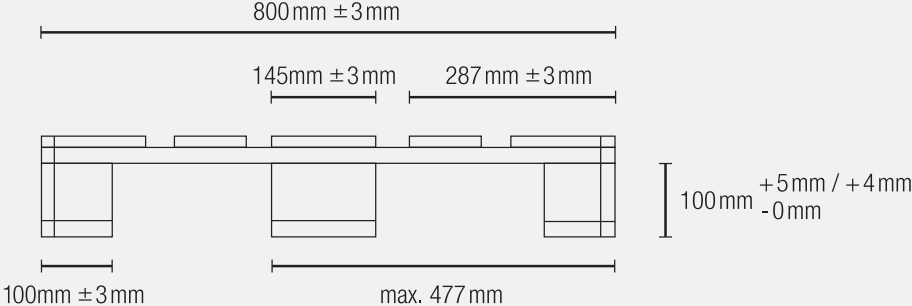

### 1200 MM SIDE

---

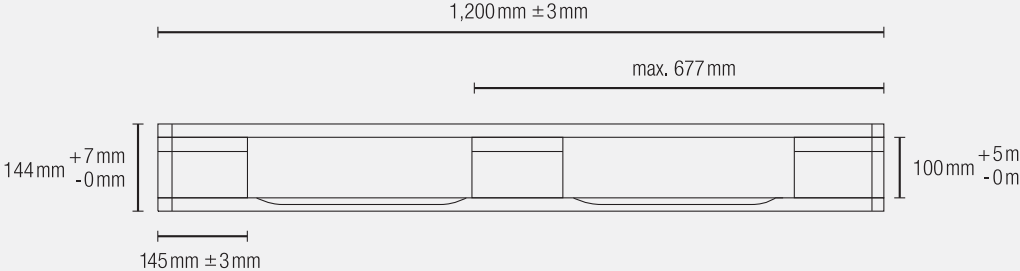

### TOP VIEW

---

